

CLEARING AND GRADING STANDARD NOTES

1. ALL CLEARING & GRADING CONSTRUCTION MUST BE IN ACCORDANCE WITH CITY OF MERCER ISLAND CLEARING & GRADING CODE; CLEARING & GRADING EROSION CONTROL STANDARD; LAND USE CODE; UNIFORM BUILDING CODE; PERMIT CONDITIONS; AND ALL OTHER APPLICABLE CODES, ORDINANCES, AND STANDARDS. THE DESIGN ELEMENTS WITHIN THESE PLANS HAVE BEEN REVIEWED ACCORDING TO THESE REQUIREMENT. ANY VARIANCE FROM ADOPTED EROSION STANDARDS IS NOT ALLOWED UNLESS SPECIFICALLY APPROVED BY THE CITY OF MERCER ISLAND PUBLIC WORKS AND COMMUNITY DEVELOPMENT (PCD) PRIOR TO CONSTRUCTION.

IT IS THE SOLE RESPONSIBILITY OF THE APPLICANT AND THE PROFESSIONAL CIVIL ENGINEER TO CORRECT ANY ERROR, OMISSION, OR VARIATION FROM THE ABOVE REQUIREMENTS FOUND IN THESE PLANS. ALL CORRECTIONS WILL BE AT NO ADDITIONAL COST OR LIABILITY TO THE COB. ALL DETAILS FOR STRUCTURAL WALLS, ROCKERIES OVER FOUR FEET IN HEIGHT, GEOGRID REINFORCED ROCKERIES, AND GEOGRID REINFORCED MODULAR BLOCK WALLS MUST BE STAMPED BY A PROFESSIONAL ENGINEER.

2. A COPY OF THE APPROVED PLANS MUST BE ON-SITE DURING CONSTRUCTION. THE APPLICANT IS RESPONSIBLE FOR OBTAINING ANY OTHER REQUIRED OR RELATED PERMITS PRIOR TO BEGINNING CONSTRUCTION.

3. ALL LOCATIONS OF EXISTING UTILITIES HAVE BEEN ESTABLISHED BY FIELD SURVEY OR OBTAINED FROM AVAILABLE RECORDS AND SHOULD, THEREFORE, BE CONSIDERED ONLY APPROXIMATE AND NOT NECESSARILY COMPLETE. IT IS THE SOLE RESPONSIBILITY OF THE CONTRACTOR TO INDEPENDENTLY VERIFY THE ACCURACY OF ALL UTILITY LOCATIONS AND TO DISCOVER AND AVOID ANY OTHER UTILITIES NOT SHOWN WHICH MAY BE AFFECTED BY THE IMPLEMENTATION OF THIS PLAN.

4. THE AREA TO BE CLEARED AND GRADED MUST FLAGGED BY THE CONTRACTOR AND APPROVED BY THE CLEARING & GRADING INSPECTOR PRIOR TO BEGINNING ANY WORK ON THE SITE.

5. A REINFORCED SILT FENCE MUST BE INSTALLED AS SHOWN ON THE APPROVED PLANS OR PER THE CLEARING & GRADING INSPECTOR, ALONG SLOPE CONTOURS AND DOWN SLOPE FROM THE BUILDING SITE.

6. A HARD-SURFACE CONSTRUCTION ACCESS PAD IS REQUIRED. THIS PAD MUST REMAIN IN THE PLACE UNTIL PAVING IS INSTALLED.

7. CLEARING WILL BE LIMITED TO THE AREAS WITHIN THE APPROVED DISTURBANCE LIMITS, EXPOSED SOILS MUST BE COVERED AT THE END OF EACH WORKING DAY WHEN WORKING FROM OCTOBER 1ST THROUGH APRIL 30. FROM MAY THROUGH SEPTEMBER 30, EXPOSED SOILS MUST BE COVERED AT THE END OF EACH CONSTRUCTION WEEK AND ALSO AT THE THREAT OF RAIN.

8. ANY EXCAVATED MATERIAL REMOVED FROM THE CONSTRUCTION SITE AND DEPOSITED ON THE PROPERTY WITHIN THE CITY LIMITS MUST BE DONE IN COMPLIANCE WITH VALID CLEARING & GRADING PERMIT. LOCATIONS FOR THE MOBILIZATION AREA AND STOCKPILED MATERIALS MUST APPROVED BY THE CLEARING & GRADING INSPECTOR AT LEAST 24 HOURS IN ADVANCE OF ANY STOCKPIILING.

9. TO REDUCE THE POTENTIAL FOR EROSION OF EXPOSED SOILS, OR WHEN RAINY SEASON CONSTRUCTION IS PERMITTED, THE FOLLOWING BEST MANAGEMENT PRACTICES (BMPs) ARE REQUIRED:

- * PRESERVED NATURAL VEGETATION FOR AS LONG AS POSSIBLE OR AS REQUIRED BY THE CLEARING & GRADING INSPECTOR.
- * PROTECT EXPOSED SOIL USING PLASTIC (EC-14), EROSION CONTROL BLANKETS, STRAW OR MULCH (COB GUIDE TO MULCH, RATES, AND USE CHART), OR AS DIRECTED BY THE CLEARING & GRADING INSPECTOR.
- * INSTALL CATCH BASIN INSERTS AS REQUIRED BY THE CLEARING & GRADING INSPECTOR OR PERMIT CONDITIONS OF APPROVAL.
- * INSTALL A TEMPORARY SEDIMENT POND, A SERIES OF SEDIMENTATION TANKS, TEMPORARY FILTER VAULTS, OR OTHER SEDIMENT CONTROL FACILITIES. INSTALLATION OF EXPOSED AGGREGATE SURFACES REQUIRES A SEPARATE EFFLUENT COLLECTION POND ON -SITE.

10. FINAL SITE GRADING MUST DIRECT DRAINAGE AWAY FROM ALL BUILDING STRUCTURES AT MINIMUM 2% SLOPE, PER UNIFORM BUILDING CODE.

11. THE CONTRACTOR MUST MAINTAIN A SWEEPER ON - SITE DURING EARTHWORK AND IMMEDIATELY REMOVE SOIL THAT HAS BEEN TRACKED ONTO PAVED AREAS AS RESULT OF CONSTRUCTION.

12. A PUBLIC INFORMATION SIGN LISTING 24- HOUR EMERGENCY NUMBER FOR THE CITY AND THE CONTRACTOR MAY BE PROVIDED TO THE APPLICANT AT THE TIME THE CLEARING & GRADING PERMIT IS ISSUED. THE APPLICANT MUST POST THE SIGN AT THE PROJECT SITE IN FULL VIEW OF THE PUBLIC AND THE CONTRACTORS, AND IT MUST REMAIN POSTED UNTIL FINAL SIGN -OFF BY THE CLEARING & GRADING INSPECTOR.

13. TURBIDITY MONITORING MAY BE REQUIRED AS A OF CLEARING & GRADING PERMIT APPROVAL. IF REQUIRED, MONITORING MUST BE PERFORMED IN ACCORDANCE WITH THE APPROVED TURBIDITY MONITORING PLAN AND AS DIRECTED BY THE CLEARING & GRADING INSPECTOR. MONITORING MUST DURING SITE (EARTHWORK) CONSTRUCTION UNTIL THE FINAL SIGN - OFF BY THE CLEARING & GRADING INSPECTOR.

14. ANY PROJECT THAT IS SUBJECTED TO RAINY SEASON RESTRICTIONS WILL NOT BE ALLOWED TO PERFORM CLEARING & GRADING ACTIVITIES WITHOUT WRITTEN APPROVAL FROM THE CITY ENGINEER. THE RAINY SEASON EXTENDS FROM NOVEMBER 1ST THROUGH APRIL 30.

GENERAL NOTES

1. ALL WORKMANSHIP AND MATERIALS SHALL BE IN ACCORDANCE WITH CITY OF MERCER ISLAND STANDARDS AND THE MOST CURRENT COPY OF WSDOT STANDARD SPECIFICATION FOR ROAD, BRIDGE, AND MUNICIPAL CONSTRUCTION, AND THE 2016 EDITION OF THE WASHINGTON STATE DEPARTMENT OF ECOLOGY STORMWATER MANAGEMENT MANUAL FOR THE PUGET SOUND BASIN.

2. ALL WORKS WITHIN THE PLAT AND CITY RIGHT OF WAY SHALL BE SUBJECT TO THE INSPECTION OF THE CITY ENGINEER OR DESIGNATED REPRESENTATIVE.

3. PRIOR TO ANY CONSTRUCTION INCLUDING CLEARING/LOGGING OR GRADING. THE SITE CLEARING LIMITS SHALL BE LOCATED AND FIELD IDENTIFIED BY THE PROJECT SURVEYOR OR PROJECT ENGINEER AS REQUIRED BY THESE PLANS. THE PROJECT SURVEYOR'S NAME AND PHONE NUMBER IS TOM 425-298-4412

4. THE DEVELOPER AND CONTRACTOR IS RESPONSIBLE FOR WATER QUALITY AS DETERMINED BY THE MONITORING PROGRAM ESTABLISHED BY THE PROJECT ENGINEER. THE PROJECT ENGINEERS NAME AND NUMBER IS STEVE 206-795-5674

5. PRIOR TO ANY SITE WORK, THE CONTRACTOR SHALL CONTACT THE DEPARTMENT OF PUBLIC WORKS TO SCHEDULE A PRECONSTRUCTION CONFERENCE. DUE TO FIELD CHANGES, ENGINEERED AS- BUILT IN ACCORDANCE WITH THE 2010 INTERNATIONAL BUILDING CODE SHALL BE REQUIRED PRIOR TO SITE APPROVAL.

6. THE CONTRACTOR SHALL BE RESPONSIBLE FOR OBTAINING ALL PERMITS FOR UTILITY, ROAD, AND RIGHT OF WAY CONSTRUCTION. THE CONTRACTOR FOR THIS PROJECT IS _____ CONTACT PERSON _____ MOBILE PHONE _____ EMERGENCY PHONE _____

7. THE TEMPORARY EROSION AND SEDIMENTATION CONTROL (TESC) FACILITIES SHALL BE CONSTRUCTED IN ACCORDANCE WITH THE APPROVED TESC PLANS PRIOR TO ANY GRADING OR EXTENSIVE LAND CLEARING. THESE FACILITIES MUST BE SATISFACTORILY MAINTAINED UNTIL CONSTRUCTION AND LANDSCAPING IS COMPLETED AND THE POTENTIAL FOR ON SITE EROSION HAS PASSED. SEDIMENT LADEN WATERS SHALL NOT ENTER THE NATURAL DRAINAGE SYSTEM.

8. NON COMPLIANCE WITH REQUIREMENTS FOR EROSION CONTROLS, WATER QUALITY AND CLEARING LIMITS MAY RESULT IN REVOCATION OF PROJECT PERMITS, PLAN APPROVAL AND BOND FORECLOSURES.

9. TRENCH BACKFILL OF NEW UTILITIES AND STORM DRAINAGE FACILITIES SHALL BE COMPACTED TO 95% MAXIMUM DENSITY (MODIFIED PROCTOR) UNDER ROADWAYS AND 90% MAXIMUM DENSITY (MODIFIED PROCTOR) OFF ROADWAYS. COMPACTION SHALL BE PERFORMED IN ACCORDANCE WITH SECTION 2-03.3(14) C- METHOD B AS DEFINED IN THE CURRENT EDITION OF THE APWA/WSDOT STANDARD SPECIFICATIONS FOR ROAD, BRIDGE, AND MUNICIPAL CONSTRUCTION.

10. THE OWNER AND CONTRACTOR SHALL BE RESPONSIBLE FOR LOCATING AND PROTECTING ALL EXISTING UTILITIES PRIOR TO BEGINNING CONSTRUCTION. LOCATIONS OF UTILITIES SHOWN ON CONSTRUCTION PLANS ARE BASED ON BEST RECORDS AVAILABLE AND ARE SUBJECT TO VARIATION. FOR ASSISTANCE IN UTILITY LOCATION, CALL 1-800-424-5555.

11. PRIOR TO CONSTRUCTION THE OWNER AND/OR CONTRACTOR SHALL NOTIFY THE PROJECT ENGINEER AND THE CITY ENGINEER WHEN CONFLICTS EXIST BETWEEN THE PLANS AND FIELD CONDITIONS. CONFLICTS SHALL BE RESOLVED (INCLUDING PLAN AND PROFILE REVISIONS) AND RESUBMITTED FOR APPROVAL PRIOR TO PROCEEDING WITH CONSTRUCTION.

12. THE CONTRACTOR SHALL KEEP TWO SET OF PLANS ON SITE AT ALL TIME FOR RECORDING AS BUILT INFORMATION, ONE SET SHALL BE SUBMITTED TO THE PROJECT ENGINEER, AND ONE SET SHALL BE SUBMITTED TO THE CITY ENGINEER AT COMPLETION OF CONSTRUCTION AND PRIOR TO FINAL ACCEPTANCE OF WORK.

13. A GRADING PERMIT ISSUED PURSUANT TO THE 2010 INTERNATIONAL BUILDING CODE, AND APPROVAL OF THE TEMPORARY EROSION AND SEDIMENTATION CONTROL PLAN SHALL BE OBTAINED FROM THE PLANNING DEPARTMENT PRIOR TO ANY ON SITE GRADING WORK NOT EXPRESSLY EXCEPT BY THE 2010 INTERNATIONAL BUILDING CODE.

14. PRIOR TO COMMENCEMENT OF FRAMING, FINAL DRAINAGE INSPECTION AND APPROVAL OF THE ROOF LEADER AND POSITIVE FOOTING SYSTEMS SHALL BE COMPLETED BY THE BUILDING DEPARTMENT. CONTRACTOR NEED TO SCHEDULE THE INSPECTION APPOINTMENT.

FIELD BOOK:	_____
SURVEYED:	_____
SURVEY BASE MAP:	_____
DESIGN ENTERED:	J.W
DESIGNED:	S.W
CHECKED:	S.W



TANDEM ENGINEERING CONSULTANT LLC
8822 NE 178TH ST
BOTHELL, WA 98011
(206) 795-5674

GENERAL NOTES

PARK'S RESIDENCE
8244 SE 30TH ST
MERCER ISLAND WA

SHEET
1
 OF
5
 SHEETS

C-1.00

GENERAL TESC NOTES

Temporary erosion and sedimentation control facilities (TESC) (including but not limited to temporary construction entrance, catch basin protection, silt fence installation, interceptor ditches, sedimentation ponds and straw bales) must be in place and inspected by the City of Mercer Island prior to demolition, clearing/grading, etc. Spoil piles shall be kept covered. All City streets shall be kept free of mud and construction debris. TESC facilities shall be maintained until final landscaping is completed. No sediment-laden water shall enter Lake Washington, the public storm drain system, water courses, sensitive areas or the adjacent properties. Not all of these facilities may be identified on this plan but may be required during construction. Contractor will adhere to additional requirements as conditions warrant and the project progresses, including cleaning of downstream catch basins and drainage facilities of sediment from this project.

PLAN NOTES

- Approval of this temporary erosion and sedimentation control (TESC) plan does not constitute an approval of permanent road or drainage design.
- The implementation of these TESC plans and the construction, maintenance, replacement, and upgrading of these TESC facilities is the responsibility of the owner/agent and/or their contractor until all construction is approved.
- The boundaries of the clearing limits shown on this plan shall be clearly flagged by a continuous length of survey tape (or fencing, if required) prior to construction. During the construction period, no disturbance beyond the clearing limits shall be permitted. The clearing limits shall be maintained by the owner/agent and/or their contractor for the duration of construction.
- The TESC facilities shown on this plan must be constructed prior to or in conjunction with all clearing and grading so as to ensure that the transport of sediment to surface waters, drainage systems, and adjacent properties is minimized.
- The TESC facilities shown on this plan are the minimum requirements for anticipated site conditions. During the construction period, these TESC facilities shall be upgraded as needed for unexpected storm events and modified to account for changing site conditions (e.g., additional sump pumps, relocation of ditches, hay bales and silt fences, etc.).
- The TESC facilities shall be inspected daily by the owner/agent and/or their contractor and maintained to ensure continued proper functioning. Written records shall be kept of weekly reviews of the TESC facilities during the wet season (Oct. 1 to April 30) and of monthly reviews during the dry season (May 1 to Sept. 30).
- Any areas of exposed soils, including roadway embankments, that will not be disturbed for two days during the wet season (Oct. 1 to April 30) or seven days during the dry season (May 1 to Sept. 30), shall be immediately stabilized with approved TESC methods (e.g., seeding, mulching, plastic cover, etc.).
- Any area needing TESC measures that do not require immediate attention shall be addressed within fifteen (15) days.
- The TESC facilities on inactive sites shall be inspected and maintained a minimum of once a month or within forty-eight (48) hours following a storm event.
- At no time shall more than one (1) foot of sediment be allowed to accumulate within a catch basin. All catch basins and conveyance lines shall be cleaned prior to final grading and/or paving. The cleaning operation shall not flush sediment-laden water into the downstream system.
- Stabilized construction entrances and roads shall be installed at the beginning of construction and maintained for the duration of the project. Additional measures, such as wash pads and sediment traps, may be required to ensure that all paved areas are kept clean for the duration of the project.
- Any permanent flow control facility used as a temporary settling basin shall be modified with the necessary temporary erosion control measures and shall provide adequate storage capacity.
- Where straw mulch for temporary erosion control is required, it shall be applied at a minimum thickness of 2 to 3 inches.
- Prior to the beginning of the wet season (Oct. 1), all disturbed areas shall be reviewed to identify which ones can be seeded in preparation for the winter rains. Disturbed areas shall be seeded within one week of the beginning of the wet season. The City can require seeding of additional areas in order to protect surface waters, adjacent properties, or drainage facilities.

Construction Sequence:

- Hold an onsite pre-construction meeting.
- Flag or fence clearing limits.
- Install catch basin protection, if required.
- Grade and install construction entrance(s).
- Install perimeter protection (silt fence, brush barrier, etc.).
- Construct sediment pond(s) and/or trap(s).
- Construct surface water controls (interceptor dikes, pipe slope drains, etc.) simultaneously with clearing and grading for project development.
- Maintain TESC measures in accordance with City standards and manufacturer's recommendations.
- Relocate surface water controls or TESC measures, or install new measures so that as site conditions change, the TESC is always in accordance with the City of Mercer Island Temporary Erosion and Sedimentation Control Requirements.
- Cover all areas that will be un-worked for more than two days during the wet season (Oct. 1 to April 30) or seven days during the dry season (May 1 to Sept. 30) with straw, wood fiber mulch, compost, plastic sheeting, or equivalent.
- Stabilize all areas within seven days of reaching final grade.
- Seed or sod any areas to remain un-worked for more than 30 days.
- Upon completion of the project, stabilize all disturbed areas and remove TESC measures if appropriate.

Reference: King County Surface Water Design Manual Appendix D - 10.3

LEGEND

- EXISTING ROCK WALL
- SILT FENCE - SF
- EDGE EXISTING PAVEMENT
- EXISTING PROPERTY LINE
- SITE DISTURBANCE LIMIT
- SOIL AMENDMENT AREA
- TREE PROTECTION FENCE
- TREE
- BRUSHES
- TREE DRIP LINES

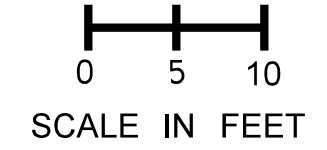
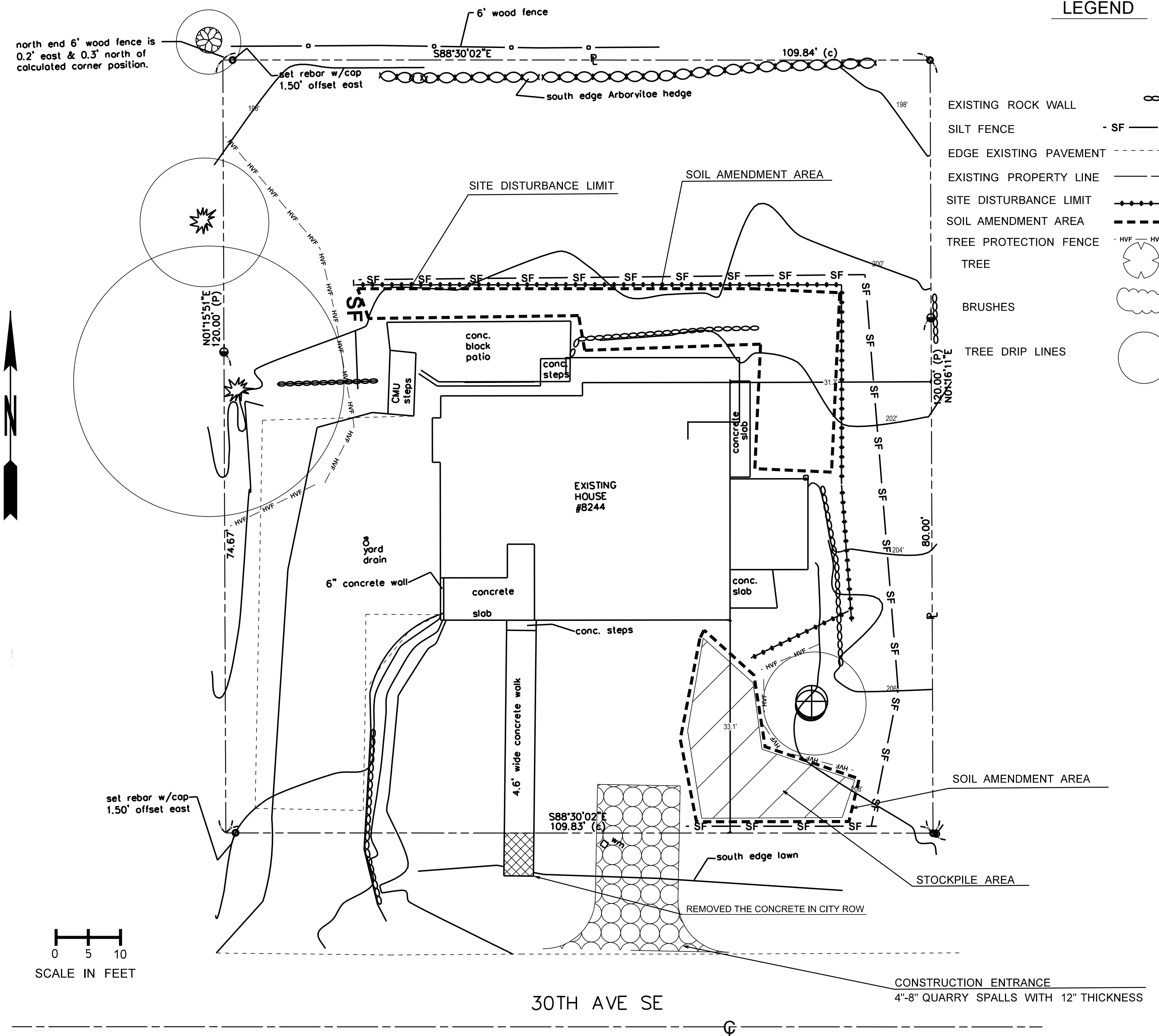

EXPOSED & STOCKPILES SOIL BMP'S

All exposed and unworked soils shall be stabilized per the following criteria:
 From October 1 to April 30, no exposed and unworked soils shall remain unstabilized (exposed) for more than two days. Non-erodible, clean, granular base materials shall be applied to stabilize all trafficked areas.
 From May 1 to September 30, no exposed and unworked soils on slopes shall remain unstabilized (exposed) for more than seven days.
 Exposed and unworked soils will be stabilized with the application of effective BMPs to prevent erosion throughout the life of the project. The specific BMPs will be used on this project include:

- Preserving natural vegetation
- Sodding
- Topsoil
- Mulching
- Check dam
- Soil binding using polyacrylamide
- Wattles
- Biodegradable erosion control blanket
- Compost blanket
- Stabilized construction entrance
- Plastic covering
- Construction road stabilization
- Seeding and planting
- Dust Control
- Bonded Fiber Matrix
- Mechanically Bonded Fiber Matrix

Seeding and mulching will be used to stabilize soils throughout the project following excavation and grading as well as other disturbed areas. During dry weather construction periods, the contractor will provide project specific dust control measures, as needed. Cut and fill slopes will be stabilized as soon as possible and soil stockpiles will be temporarily covered with plastic sheeting to prevent short-term erosion. All stockpiled soils will be stabilized from erosion, protected with sediment trapping measures, and where possible, be located away from storm drain inlets, waterways, and drainage channels.

FIELD BOOK: _____ SURVEYED: _____ SURVEY BASE MAP: _____ DESIGN ENTERED: J.W DESIGNED: S.W CHECKED: S.W		TANDEM ENGINEERING CONSULTANT LLC 8822 NE 178TH ST BOTHELL, WA 98011 (206) 795-5674	<h1 style="margin: 0;">TESC PLAN</h1>	PARK'S RESIDENCE 8244 SE 30TH ST MERCER ISLAND WA	SHEET 2 OF 5 SHEETS <hr/> C-2.00
---------------------------------------------------------------------------------------------------------------------------------------------	--	-----------------------------------------------------------------------------------------------------	---------------------------------------	----------------------------------------------------------------	----------------------------------------------------------------------

LEGEND

- EXISTING EDGE OF PAVEMENT
- SPOT ELEVATION +203
- TREE FENCE
- EXISTING TREES
- TREE DRIP LINES
- FOOTING DRAIN
- EXISTING LOT LINE

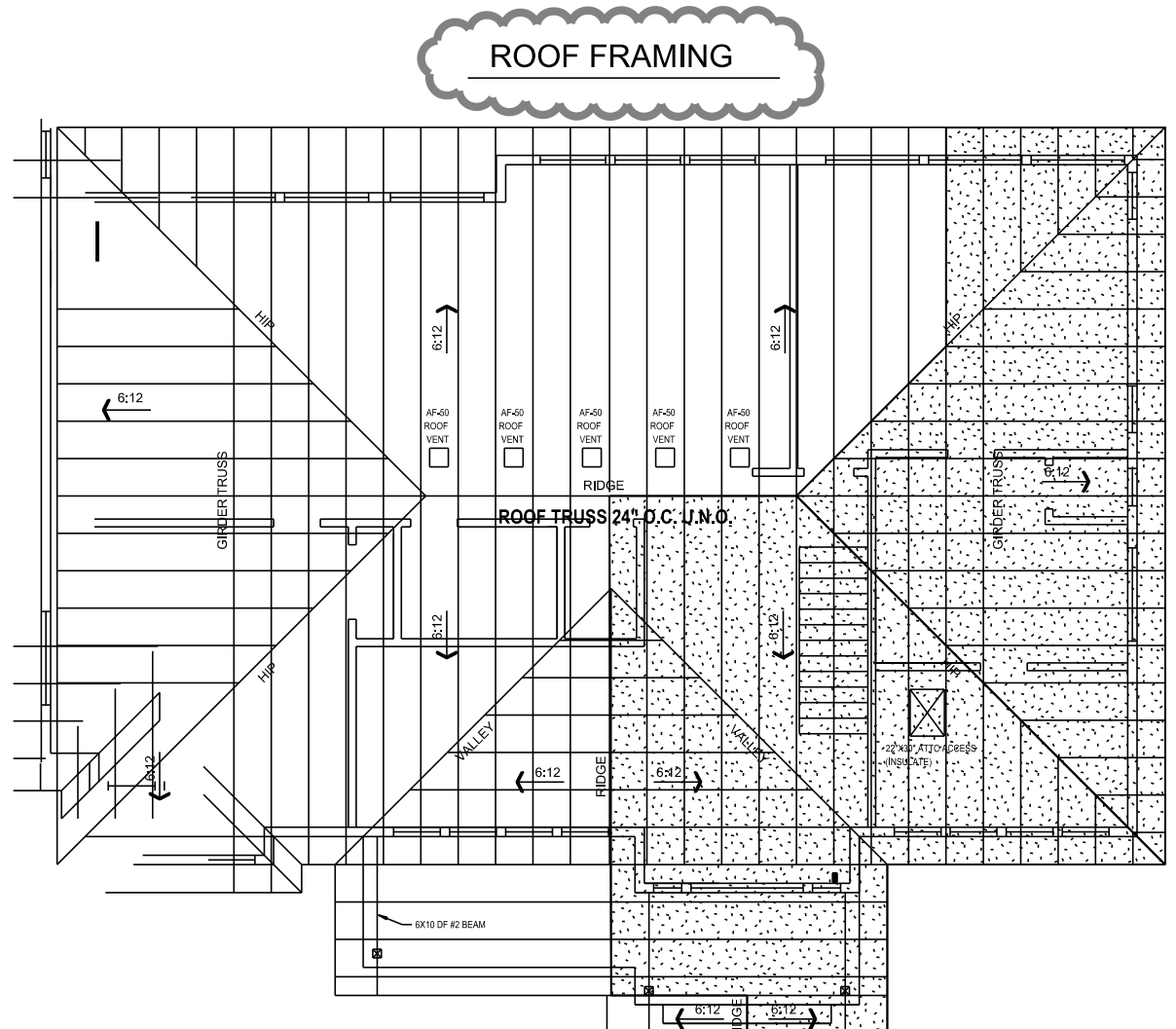

NOTE

- ① 4" FOOTING DRAIN, MIN 2.0% SLOPE, GRADE (ASTM D-3034 PVC)
- ② 4" ROOFING DRAIN, MIN 2.0% SLOPE, GRADE (ASTM D-3034 PVC)
- ③ 6" STORM WATER DRAIN, MIN 2% SLOPE, GRADE (ASTM D-3034 PVC)

TREE INVENTORY

Tree #	Species	DBH	Remarks	Condition
1	Douglas Fir	24"	21" radius dripline to east and south, 19' north	Good
2	Pine, White	16"	off-site tree co-dominant 30", risk assessment advise 10" canopy overhang	Fair
3	Western Hemlock	16"	off-site tree, 5' by 8' canopy overhang	Good
4	Japanese lace leaf maple	6"	Vigorous lace leaf worth transplanting/relocating	Excellent

NOTE

NO EXCAVATION ENCROACHMENT INTO TREE DRIP LINE

Post Construction Soil Quality

All areas subject to clearing and grading that have not been covered by impervious surface, incorporated into a drainage facility or engineered as structure fill or slope shall, at project completion, demonstrate the following:

1. A topsoil layer with a minimum organic matter content of 10% dry weight in planting beds, and 5% organic matter content in turf areas, and a pH from 6.0 to 8.0 or matching the pH of the undisturbed soil. The topsoil layer shall have a minimum depth of eight inches except where tree roots limit the depth of incorporation of amendments needed to meet the criteria. Subsoils below the topsoil layer should be scarified at least 4 inches with some incorporation of the upper material to avoid stratified layers, where feasible.
2. Mulch planting beds with 2 inches of organic material
3. Use compost and other materials that meet these organic content requirements:
 - a. The organic content for "pre-approved" amendment rates can be met only using compost meeting the compost specification for BMP T7.30: Bioretention Cells, Swales, and Planter Boxes (p.959), with the exception- that the compost may have up to 35% biosolids or manure. The compost must also have an organic matter content of 40% to 65%, and a carbon to nitrogen ratio below 25:1. The carbon to nitrogen ratio may be as high as 35:1 for plantings composed entirely of plants native to the Puget Sound Lowlands region.
 - b. Calculated amendment rates may be met through use of composted material meeting (a.) above; or other organic materials amended to meet the carbon to nitrogen ratio requirements, and not exceeding the contaminant limits identified in Table 220-B, Testing Parameters, in WAC 173-350-220.

Maintenance

1. Establish soil quality and depth toward the end of construction and once established, protect from compaction, such as from large machinery use, and from erosion.
2. Plant vegetation and mulch the amended soil area after installation.
3. Leave plant debris or its equivalent on the soil surface to replenish organic matter.
4. Reduce and adjust, where possible, the use of irrigation, fertilizers, herbicides and pesticides, rather than continuing to implement formerly established practices.

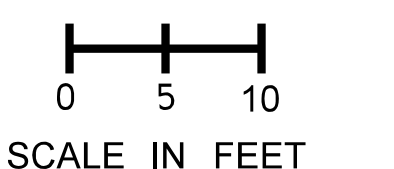
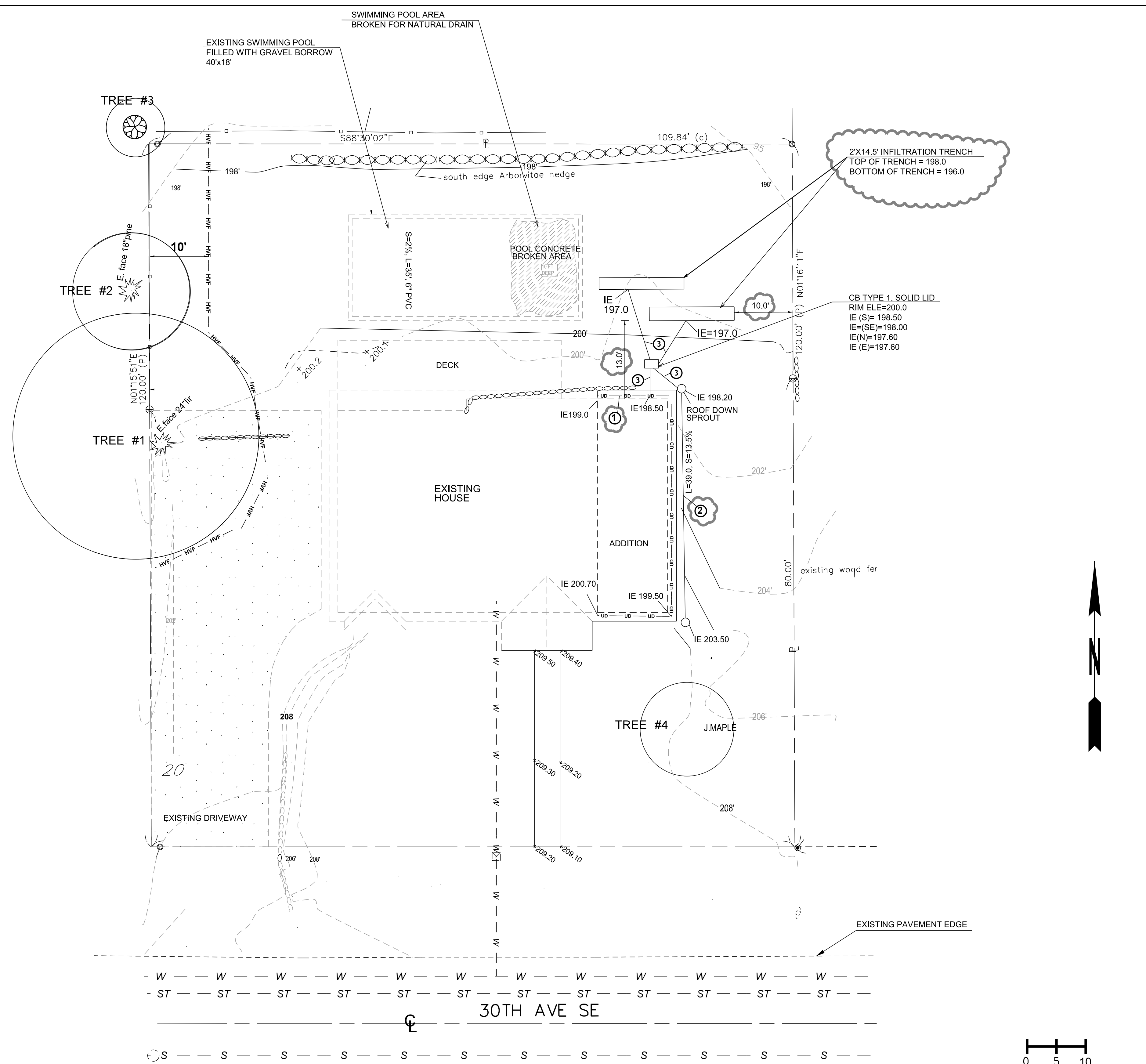

FIELD BOOK: _____
 SURVEYED: _____
 SURVEY BASE MAP: _____
 DESIGN ENTERED: **J.W**
 DESIGNED: **S.W**
 CHECKED: **S.W**



TANDEM ENGINEERING CONSULTANT LLC
 8822 NE 178TH ST
 BOTHELL, WA 98011
 (206) 795-5674

GRADATION & DRAINAGE PLAN

PARK'S RESIDENCE
 8244 SE 30TH ST
 MERCER ISLAND WA

SHEET
3
 OF
5
 SHEETS

C-3.00

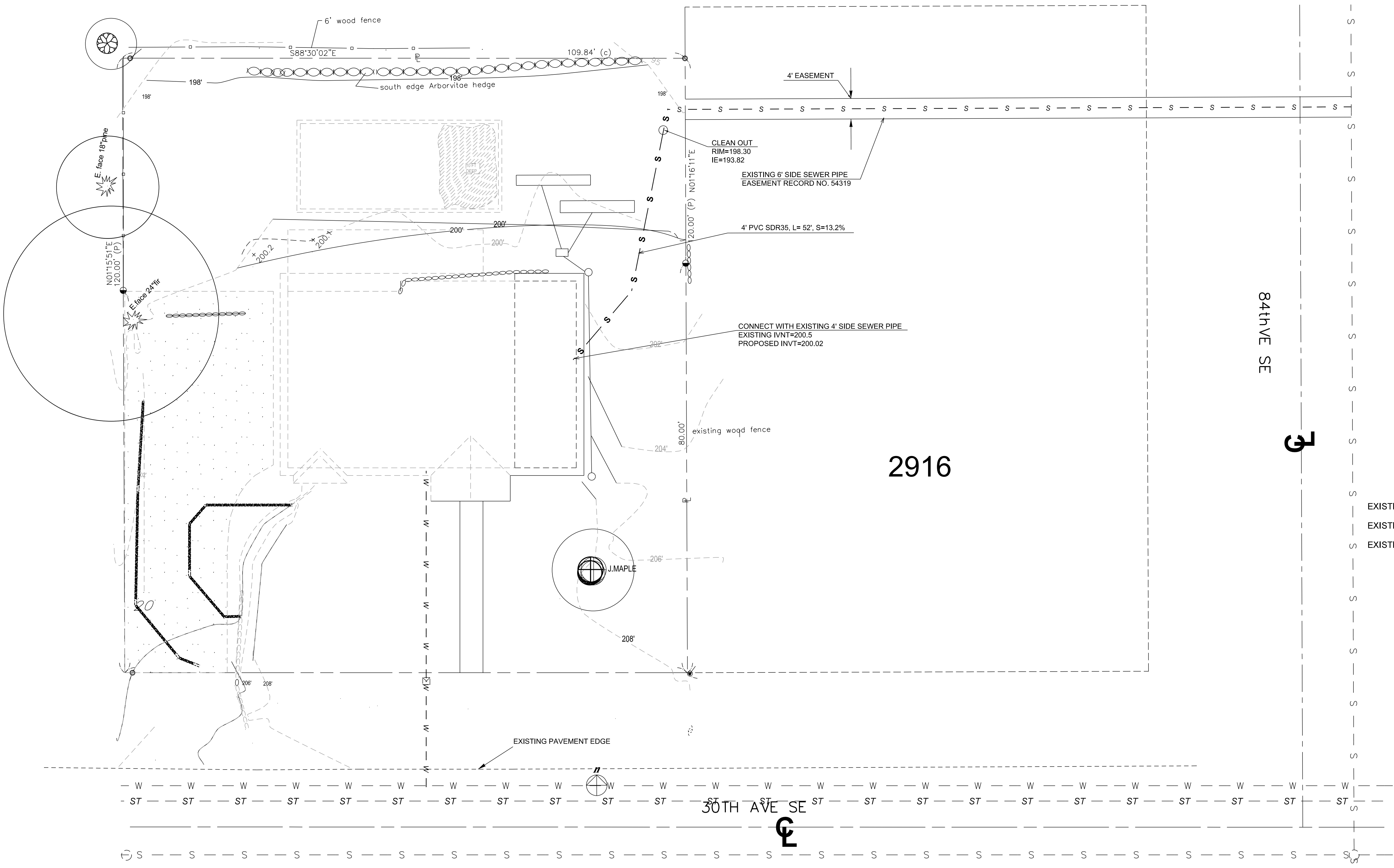

LEGEND

- EXISTING SEWER LINE - S - - - S - - -
- EXISTING WATER LINE - W - - - W - - -
- EXISTING STORM DRAIN - ST - - - ST - - -

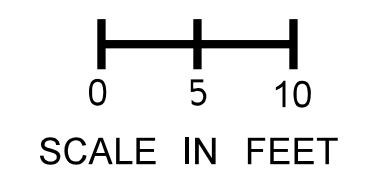

FIELD BOOK: _____
 SURVEYED: _____
 SURVEY BASE MAP: _____
 DESIGN ENTERED: **J.W**
 DESIGNED: **S.W**
 CHECKED: **S.W**



TANDEM ENGINEERING CONSULTANT LLC
 8822 NE 178TH ST
 BOTHELL, WA 98011
 (206) 795-5674

SEWER & WATER LINE

PARK'S RESIDENCE
 8244 SE 30TH ST
 MERCER ISLAND WA

SHEET
4
 OF
5
 SHEETS

C-4.00

Figure II-3.1: Stabilized Construction Access

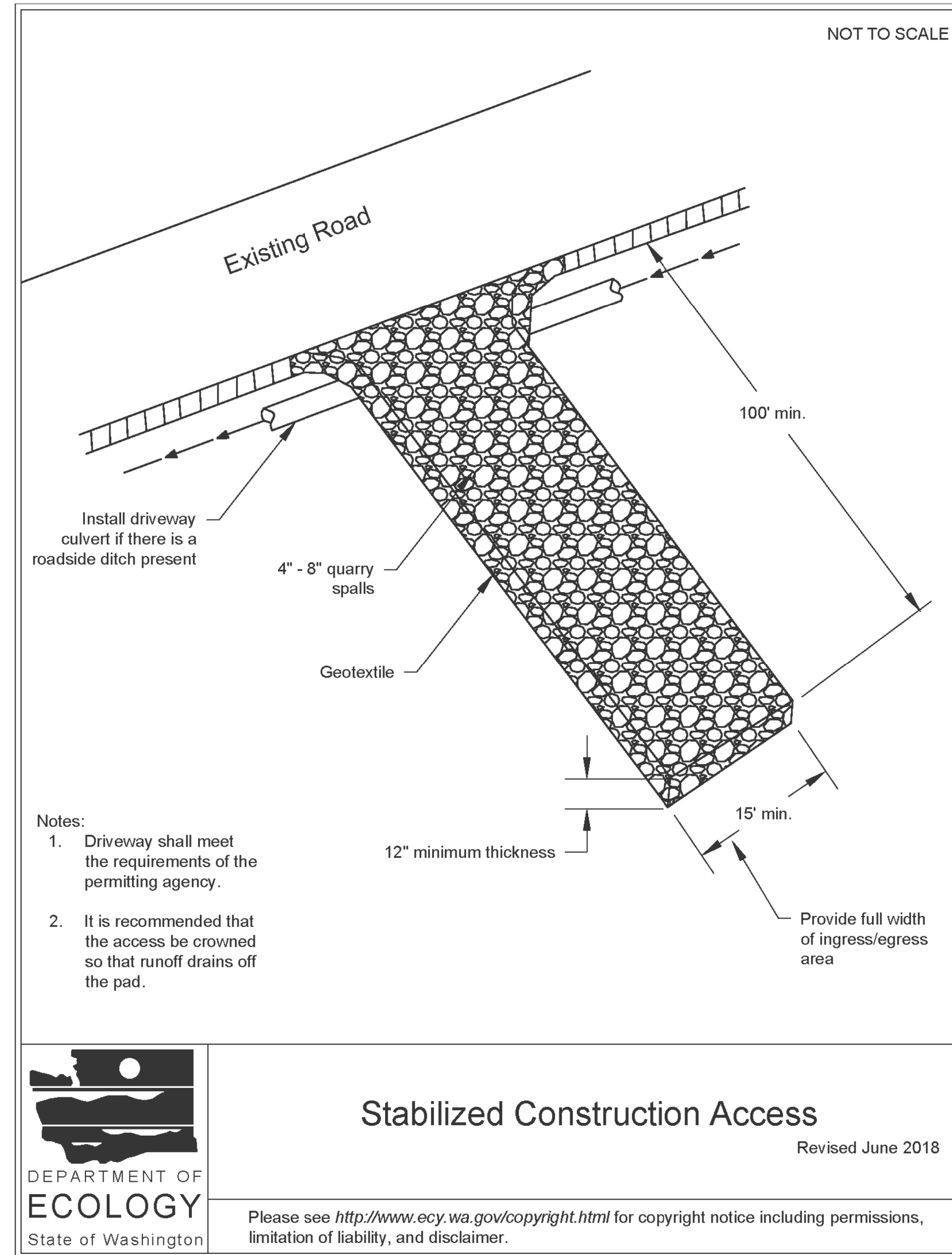

NTS

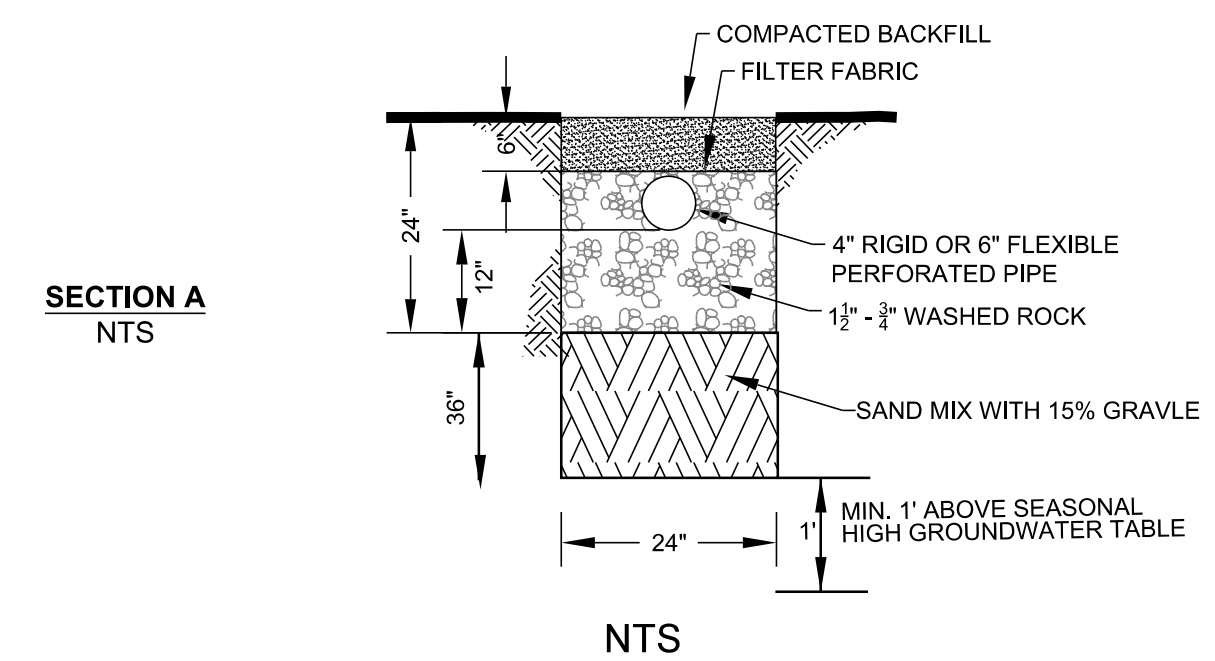
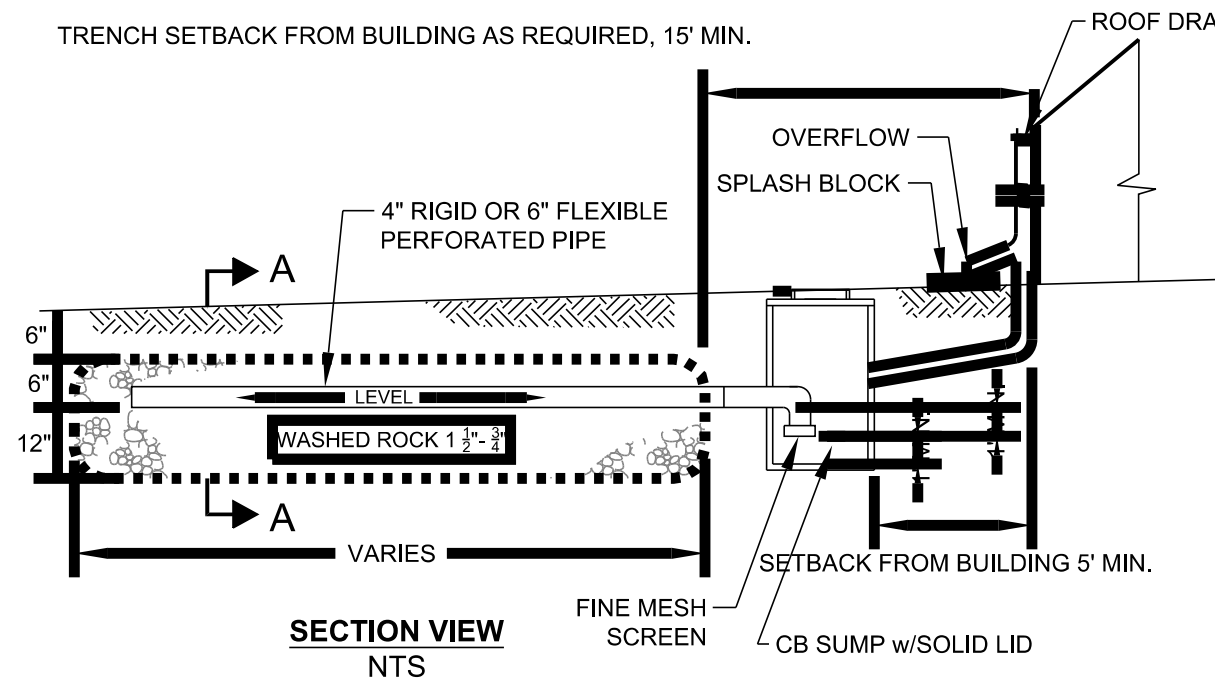
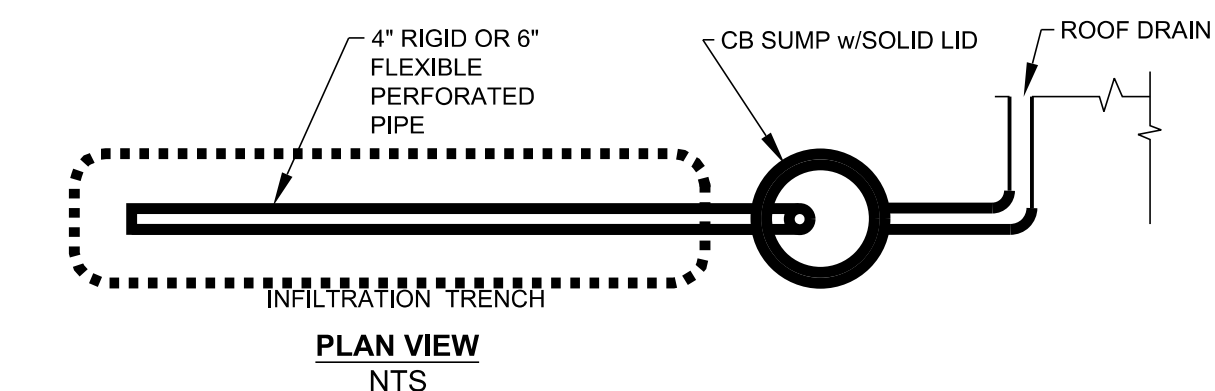

NTS

FIELD BOOK: _____
 SURVEYED: _____
 SURVEY BASE MAP: _____
 DESIGN ENTERED: **J.W**
 DESIGNED: **S.W**
 CHECKED: **S.W**

TANDEM ENGINEERING CONSULTANT LLC
 8822 NE 178TH ST
 BOTHELL, WA 98011
 (206) 795-5674

DETAILS

PARK'S RESIDENCE
 8244 SE 30TH ST
 MERCER ISLAND WA

SHEET
5
 OF
5
 SHEETS

C-5.00